

NOTICE - PROPRIETARY INFORMATION
 THE DESIGN AND RELATED INFORMATION CONTAINED HEREIN IS THE SOLE PROPERTY OF COFAN INC. THE DISCLOSURE OF THIS INFORMATION DOES NOT CONSTITUTE THE RELEASE OF ANY PROPRIETARY RIGHTS THEREIN. PERMISSION TO REPRODUCE THIS INFORMATION OR THE PRODUCTS DISCLOSED HEREIN MUST BE OBTAINED IN WRITING FROM COFAN INC.

REVISION HISTORY					
REV	DESCRIPTION	DRWN	CHK'D	APPVD	DATE
—	— SEE SHEET 1	—	—	—	—

- NOTES:
- MATERIAL: AL 6063-T5.
 - FINISH: BLACK ANODIZE.
 - BREAK ALL SHARP EDGES AND CORNERS.
 - ALL DIMENSIONS ARE TOLERANCED BY THE DECIMAL PLACE ON THE DRAWING AND IN THE TITLE BLOCK UNLESS NOTED ON THE DRAWING BY A SEPARATE TOLERANCE CALLOUT.
 - IS CRITICAL INSPECTION POINT. NUMBERING IN TRIANGLES IS TO BE USED FOR CROSS REFERENCE OF INSPECTION REPORT TO DRAWING DIMENSION OR FEATURE.
 - ATTACH HEAT SINK TO BGA USING LOCTITE 384 THERMAL EPOXY AND LOCTITE 7387 ACTIVATOR (NOT INCLUDED WITH SEAT SINK)

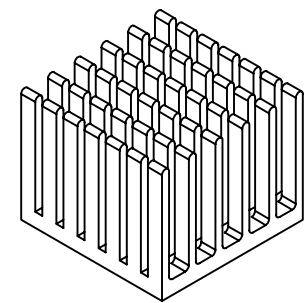
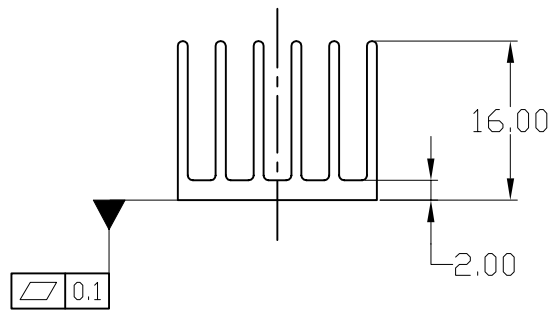
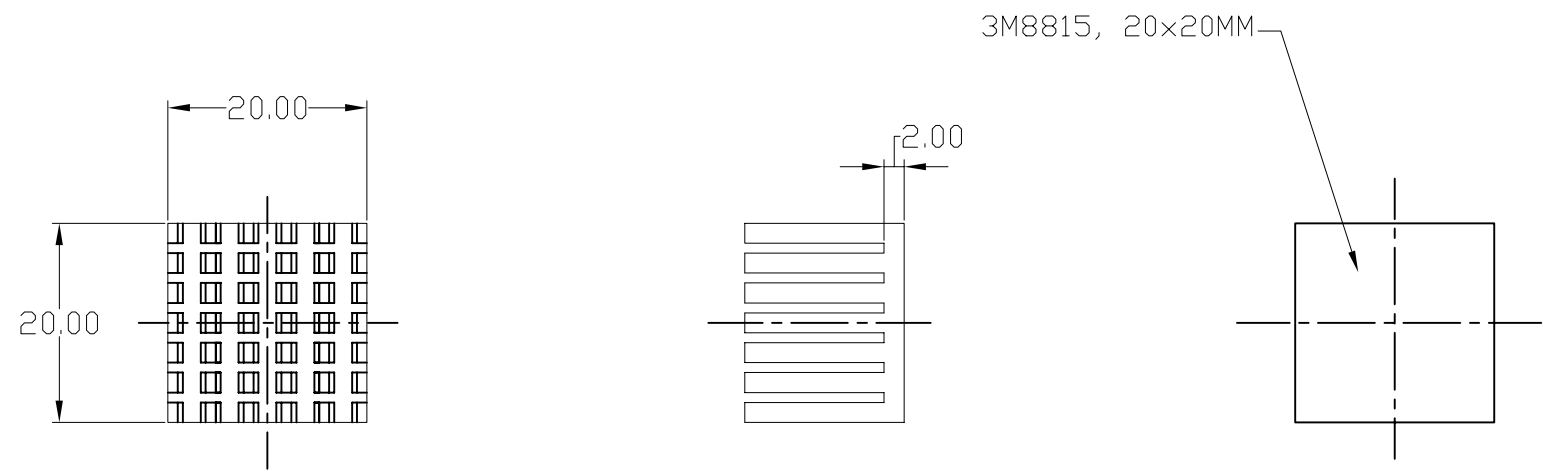

RoHS
 Compliant
 2002/95/EC

DO NOT SCALE DRAWING <small>UNLESS OTHERWISE SPECIFIED DIMENSIONS ARE IN MILLIMETRE TOLERANCES ARE:</small> 1 PLACE .X ± 0.4 2 PLACE .XX ± 0.25 3 PLACE .XXX ± 0.13 ANGLES EXCEPT 90° ± 0.5° MAXIMUM SURFACE ROUGHNESS 6.3√	MATERIAL: 1	CUSTOMER DRAWING NUMBER: ----	 <small>46177 WASH SPRINGS BLVD. FREMONT CA 94539</small>		
	FINISH: 2	CUSTOMER PART NUMBER: NAME: 20X20X16MM, HEAT SINK			
	DRAWN BY: Long	COFAN DRAWING NUMBER: 30-2008	SCALE: 1:1	CUS REV: A	COF REV: 01
	CHECKED BY: IVAN.C	COFAN PART NUMBER: 30-2008	SHEET: 1 OF 1	DATE DRAWN: AUG-4-2006	